





2 SERIES

<http://tiny.cc/multione2-2EN>

 TIPPING LOAD 530 kg	 ENGINE POWER 25 hp	 SPEED 15 km/h	 FLOW RATE 42 l/min	 LIFT HEIGHT 1,6 m
---	---	---	--	---

Tires size	Width (N)
20x8.00-10	1035 mm (40.7 in)
23x8.50-12	1020 mm (40.2 in)

Model	2.3
Engine	B&S Vanguard 8270
Power (Iso Gross)	25 HP
Fuel	Petrol
Transmission	Hydrostatic
Drive speed (max.)	15 km/h (9.3 mph)
Aux. hydraulics oil flow	42 l/min (11.1 GPM)
Max. lifting height	1,6 m (63 in)
Tipping load, max ⁽¹⁾	530 kg (1168 lbs)
Lifting capacity straight ⁽²⁾	420 kg (926 lbs)
Lifting capacity fully articulated ⁽³⁾	340 kg (750 lbs)
Breakout force / 50 cm (19.7 in)	500 kg (1102 lbs)
Pushing force (c)	800 kgf (800 kp)
Specific ground pressure (w/standard tires)	610 kg/m ² (125 lbs/sqft)
Turning radius: inside/outside	700 / 1698 mm (27.6 / 66.9 in)
Standard tires (Tractor profile)	20x8.00-10
Weight	700 kg (1543 lbs)
Product Code	C951027
Price	

⁽¹⁾ Maximum load that can be lifted just off the ground when the machine is straight and with back-weights. Weight of attachment included.

⁽²⁾ Machine straight, with back-weights. Weight of attachment is included. (80% of tipping load).

⁽³⁾ Machine fully articulated, with back-weights. Weight of attachment is included.

2 SERIES - FEATURES AND OPTIONS

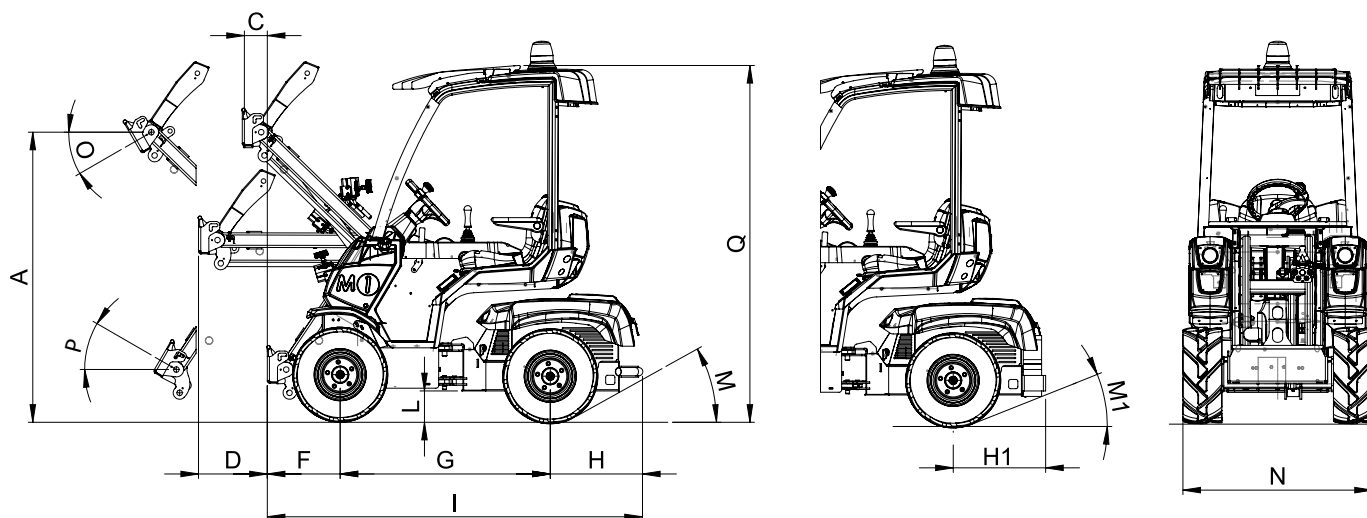

Dimensions (mm / in)

A - Pivot point height (not extended boom)	1584 / 62.3	L - Ground clearance	171 / 6.7
C - Outreach with lifted boom	125 / 4.9	M - Angle of departure	29°
D - Outreach with orizontal boom	375 / 14.7	M1 - Angle of departure with back-weights	21,5°
F - Front length	398 / 15.6	N - Max width (with standard tires)	1035 /40.7
G - Wheelbase	1147 / 45.1	O - Dump angle	40°
H - Rear length	504 / 19.8	P - Rollback angle	39°
H1 - Rear length with back-weights	504 / 19.8	Q - Height (with standard tires)	1948 / 70.7
I - Machine length	2049 / 80.6		

Features

- 4WD hydrostatic Direct Drive motors, proportional servo
- DBS (Dynamic Block System)
- Hydraulic oil cooler
- Hydraulic multiconnector
- Self-levelling H-frame boom
- 4-functions joystick
- ROPS-FOPS Level I
- 2 front working light
- Ergonomic seat with armrests and safety belt, adjustable position
- Mechanical parking brake

2 SERIES - FEATURES AND OPTIONS

Options		Code	Price
Driver area cover		C880049	
Multiconnector to quick coupling 3 lines adapter		C880221	
Additional back-weights 84 kg (185 lbs)		C880234	
Trailer coupling		C880235	
Backup warning beeper		C883021	
Beacon light		C883039	
Biodegradable oil		C883200	
Tractor tires 23x8.50-12, set of 4		C884005	
Grass tires 23x8.50-12, set of 4		C884006	
Torque divider		C885016	
Left protection bar for operator		C885027	
Grass profile tires 20x8.00-10, set of 4		C885211	
Fully glass cab with heating system		C885224	
Heated seat		C885225	
LED Road lights		C885229	
3 Additional working lights, LED		C885230	
Smart cabin with heating system		C885233	
Snow chains for wheel		see page 64	
Machine packages		Code	Price
2.3	ALL SEASON: Fully glass cab + Heating system	C951027/AS	
	COMFORT: Heated seat + 3 additional working LED lights	C951027/C	