



5055

All Wheel Steer Loaders



5055 All Wheel Steer Loader

The 5055 all wheel steer wheel loader offers excellent maneuverability around the job site. This unit features a long wheelbase for smooth driving and easy handling even across the roughest terrain. Counterweights are located far behind the rear axle for higher payloads and more stability. Four-wheel drive steering offers excellent maneuverability, overall machine stability and increased payloads. Machine design features placement of components for easy access and serviceability.

- Operator station offers a spacious and functional layout for operator comfort.
- All-wheel steer and rigid frame provide excellent maneuverability and constant payload stability even when turning.
- Hydraulically operated universal style quick hitch allows for efficient changing from one accessory to another without leaving the operator's station.
- Engine cover lifts high giving excellent access to all the service points.
- Low transport weight and constant high payload make this the ideal machine.



5055 Technical specifications

	5055 Cabin	5055 Canopy
Engine / Motor		
Engine / Motor manufacturer	Yanmar	Yanmar
Engine / Motor type	4NNKAC Tier IV Final	4NNKAC Tier IV Final
Engine performance hp	47	47
Displacement in ³	133.6	133.6
Electrical system		
Operating voltage V	12	12
Battery Ah	74	74
Alternator A	55	55
Weights		
Operating weight lb	7,936.6	7,605.9
Lifting force lb	7,306.3	
Breakout force lbf	6,294.6	6,294.6
Payload S=1.25 (pallets) lb	3,527.4	3,527.4
Tipping load max. lb	4,761.9	4,761.9
Vehicle data		
Bucket capacity yd ³	0.85	0.85
Speed mph	0-12.4	0-12.4
Standard tires	10.5-18	10.5-18
Service brake	Hydraulic disc brake	Hydraulic disc brake
Steering angle max. °	2 x 38	2 x 38
Hydraulic system		
Driving hydraulics - discharge capacity US gpm	14.56	
Operating hydraulics - operating pressure psi	3,408.4	3,408.4
Filling capacities		
Tank capacity US gal	15.6	15.6
Hydraulic oil tank US qt	61.3	61.3

We reserve the right to make modifications without prior notice. No responsibility is taken for the accuracy of this information. The provisions of the contractual agreement shall be considered definitive.



5055 Dimensions

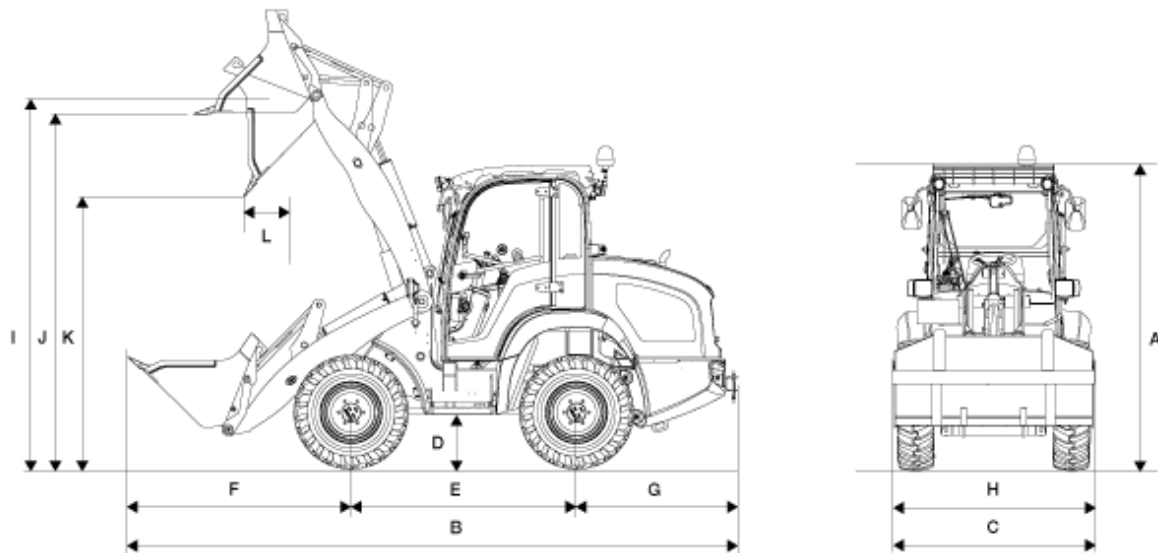

Dimensions

A	Height	93.7 in
B	Overall length	194.9 in
C	Overall width	62.6 in
D	Ground clearance	10.6 in
E	Wheelbase	72.8 in
F	Center of front axle to tip of teeth	70.1 in
G	Center of rear axle to end of vehicle	52 in
H	Bucket width	65 in



I	Hinge pin height	119.7 in
J	Overhead loading height max.	113.8 in
K	Dump height max.	91.3 in
L	Dump reach	11.8 in
	Stack height max.	111 in
	Radius Wheel outside edge	106.3 in

Please note

that product availability can vary from country to country. It is possible that information / products may not be available in your country. More detailed information on engine power can be found in the operator's manual; the stated power may vary due to specific operating conditions.

Subject to alterations and errors excepted. Applicable also to illustrations.

Copyright © 2019 Wacker Neuson SE.