



CMC MODEL

# 60HD<sup>+</sup>

ARBOR PRO



**TECHNICAL DATA SPECSHEET**



# 60HD+ ARBOR PRO

## UNIQUE FEATURES



- 62' working height
- Up to 38' lateral side reach
- 29.5' lateral reach when outriggers are in narrow position
- Capable of entering 36" gates
- Single man aluminum tubing basket
- Simple hydraulics, no computers
- Fast boom operation
- 485 lbs basket capacity
- Multi setup outriggers -- can be setup in narrow or wide positions.
- Narrow outrigger setup allows full rotation (720°)
- Smooth proportional controls
- Automatic smoothing of controls while parking booms and at maximum reach
- Wireless remote control for driving the tracks
- Ability to lift upper boom for better ground clearance while driving tracks
- Extraordinarily powerful track drive
- Extra large rubber tracks (6' long, 10" wide)
- Kubota diesel engine included
- Set of 4 specialty sliding outrigger pads stay on the feet of the outriggers
- Single handed operation
- Designed specifically for the tree care industry
- Ability to setup & automatically level on up to 19° or 34% grade
- Operate up to 2 functions simultaneously
- Basket leveling from both inside the basket & from the ground

## STANDARD FEATURES // AERIAL LIFT



- 62' working height
- Fast fully-proportional controls for smooth operation
- Can perform 2 functions at the same time at full speed
- Hydraulic hoses and control cables inside booms for complete protection, with easy service access
- Telescoping boom sections with hydraulic cylinders and leaf drive chains
- Upper boom with two telescopic extensions
- Single man fiberglass basket (rotation optional)
- Easy basket access equipped with drop down safety bar and retractable ladder
- Automatic basket leveling
- Rotating turret +/- 720°
- Live hydraulic (emergency) let down system
- Greaseless booms

## STANDARD FEATURES // OUTRIGGERS



- Ability to setup automatically on up to 19° or 34% grade
- 4 live hydraulic outriggers with automatic leveling
- Waterproof safety switches located in well-protected positions
- Dual lock valves on all hydraulic cylinders
- Outrigger feet with articulating pad made of special anti-slip polymetric plastic to ensure additional safety
- Multi-position outriggers with the ability to setup 8' 9" narrow or 11' 6" wide



**Have questions? Get in touch with us:**

Office: 717-684-5050  
 info@slaymargroup.com  
 slaymargroup.com

# 60HD+ ARBOR PRO

## STANDARD FEATURES // CHASSIS



- Wireless remote control for fully proportional track drive system
- Ultra strong hydraulic motor track drive
- Heavy duty turret rotation motor and gear box

### Rubber tracks:

- High quality steel reinforced rubber tracks
- Horizontally adjustable tracks allow for adjustment from 34½" to 50" wide for travel through a 36" gate or on difficult terrain
- Ability to rotate tracks while machine is stabilized on the outriggers for easy maintenance or replacement
- Able to climb slopes up to 17° or 30% -- But can also continue on to over 31° / 60% when user overrides the standard setting.
- Cross hill slope travel up to 17° or 30% -- But can also continue to travel 31° / 60% when user overrides the standard setting

### Wide and long tracks for:

- ▶ Superior climbing ability
- ▶ Better weight distribution—low PSI under the tracks. No damage to lawns, stone, tile, or other sensitive ground
- ▶ Travel speed up to 1.5 mph
- Fully enclosed and protected hydraulic

motor system with easy access for routine maintenance

- Hydraulic tank level sight glass
- Engine key start and stop with hour meter
- Hydraulic hoses protected
- Ability to travel with upper boom raised to facilitate hill climbing
- 4 tie down points for transport on truck or trailer. Points can also be used for crane lift
- Easy access engine compartment for maintenance
- Easy access battery compartment
- Lockable wireless remote control storage box



## STANDARD FEATURES // REMOTE CONTROLS



- Simpler & intuitive controls
- Simple hydraulic levers for each function
- Multi-function LED display for machine status
- Capability to use the remote to stabilize & transport the lift
- Plug in the remote to the lift operate booms from basket
- Notification LED which indicates when the booms are centered
- Notification LED which indicates that the chassis is level, and the booms are ready to fly.
- Battery charger for included spare radio remote control battery in storage compartment so there is always a fully charged battery available for the radio remote control
- Radio remote control will still work when connected via cable, even if the battery is low
- Chassis spirit (bubble) level
- Key start/stop for Kubota diesel engine
- Electric motor start/stop (optional)

## STANDARD FEATURES // POWER



- Kubota diesel Z602 engine

### OPTIONAL

- Plug in electric 120V 20A -- Hybrid

## STANDARD FEATURES // SAFETY



- ANSI (US) and (CSA) Canada certified
- Design and construction far exceed safety standards
- Redundant safety systems
- Dual lock valves on all hydraulic cylinders
- Chassis out of level safety system
- Waterproof safety switches placed in well protected positions
- Emergency stop button within reach of operator and ground personnel
- Basket weight sensor and overload alarm: meets new 2017 OSHA standard



# 60HD+ ARBOR PRO

## STANDARD FEATURES // GENERAL



- High quality, HSLA (high strength low alloy) steel booms
- All hoses & cables protected on entire machine, ready for rugged outdoor use
- Nickel plated bushings and pins
- All high quality, waterproof safety switches are used
- “Plug and play” cables and hoses
- Greaseless booms
- Bushings and grease fittings on every pivot point
- Tight tolerances on pivot points
- 5 Step paint process: sand blasting, body work, two coats of primer, and two coats of finish paint

## OPTIONAL FEATURES



- 12V Battery backup for booms: \$980
- Non-marking rubber tracks upgrade: \$1,250/set
- High pressure air/water outlet in the basket: \$650
- 8-10 GPM hydraulic tool outlet in basket: \$3,850
- Track socks: \$298
- 120V 20A Electric plug in the basket: \$750
- 120V 20A Plug-in electric motor: \$3,250
- Custom specialty lightweight & heavy duty steel trailer with ability to use lift directly from the trailer: \$7,500
- Custom specialty lightweight aluminum trailer: \$ask
- Enclosed trailer: \$ask
- Set of 4 cavity outrigger pads: \$600
- Custom color: \$1,980
- Two custom colors: \$2,480
- Additional fall arrest aerial lift harness and lanyard kit including storage bag: \$69
- Custom decal lettering: (ask for more details & pricing)



### Have questions? Get in touch with us:

Office: 717-684-5050  
info@slaymakergroup.com  
slaymakergroup.com

## TECHNICAL SPECIFICATIONS



### PERFORMANCE

	Maximum working height . . . . .	62'
	Maximum lateral reach at 200 lbs . . . . .	38'
	Maximum lateral reach at 250 lbs . . . . .	35'
	Maximum lateral reach at 485 lbs . . . . .	33'
	Maximum weight load with standard basket . . . . .	485 lbs
	Turret rotation . . . . .	+/- 720°
<b>P</b>	Maximum slope to stabilize (deployment) . . . . .	19° (34%)
	Tracks extension . . . . .	34 1/2" - 50"
<b>W</b>	Maximum slope approach angle / slope . . . . .	30° (57%)
<b>X</b>	Gradeability -- max. travel angle / slope* . . . . .	19° (34%)
	Maximum crawler travel speed . . . . .	0 - 1.5 mph

\*This is the standard setting. The standard setting can be overridden to: 31° (60.1%)  
\*\*3 speeds: Slow, Slow with Torque, Fast

### DIMENSIONS

<b>A</b>	Basket height . . . . .	43"
<b>B</b>	Basket width . . . . .	32"
<b>C</b>	Basket length . . . . .	25"
<b>D</b>	Total length . . . . .	15' 6"
<b>F</b>	Height in transport mode . . . . .	80"
<b>G</b>	Total width (without basket) . . . . .	35"
<b>H</b>	Free height from the ground . . . . .	7"
<b>I</b>	Tracks (LxW) . . . . .	69" x 10"
<b>J</b>	Outrigger spread length in narrow position . . . . .	13' 6"
<b>K</b>	Outrigger spread width in narrow position . . . . .	8' 9"
<b>L</b>	Outrigger spread length in wide position . . . . .	11' 6"
<b>M</b>	Outrigger spread width in wide position . . . . .	11' 6"
<b>N</b>	Outrigger (stabilizer) plate (foot) diameter . . . . .	7"
	~Outrigger specialty pad . . . . .	8" x 22"

### WEIGHTS

	Total Weight . . . . .	6,200 lbs
<b>R</b>	Maximum outrigger point load pressure* . . . . .	23.9 psi
<b>S</b>	Maximum track ground pressure stationary . . . . .	4.7 psi
	weight is dispersed in 3' x 6' floor area	
<b>T</b>	Maximum pressure in travel . . . . .	2.4 psi
	weight is dispersed in 9' x 12' floor area	
<b>U</b>	Maximum outrigger point load in normal work position . . . . .	9.9 psi



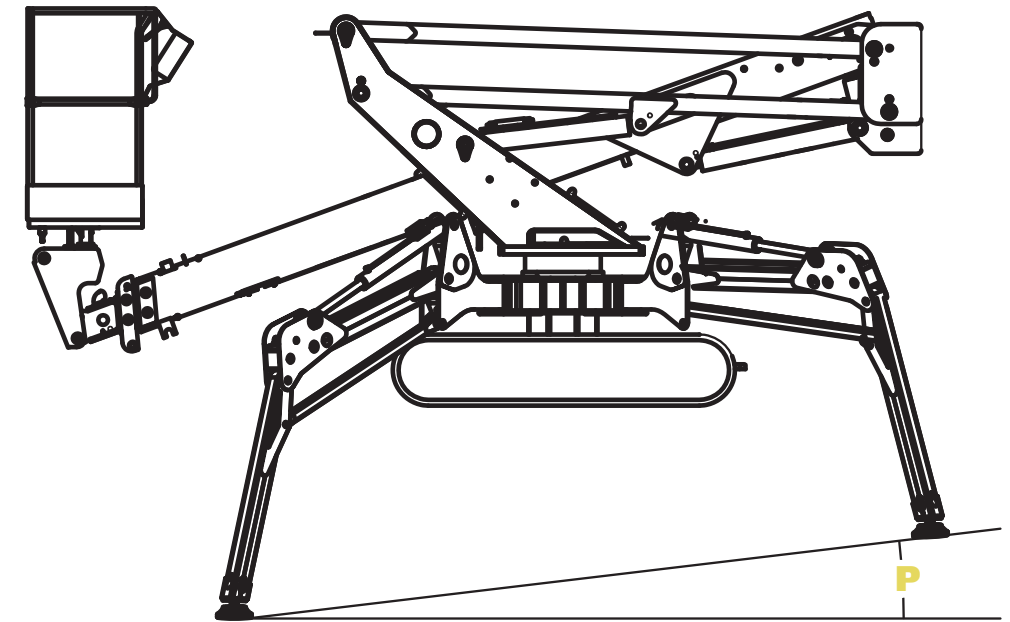
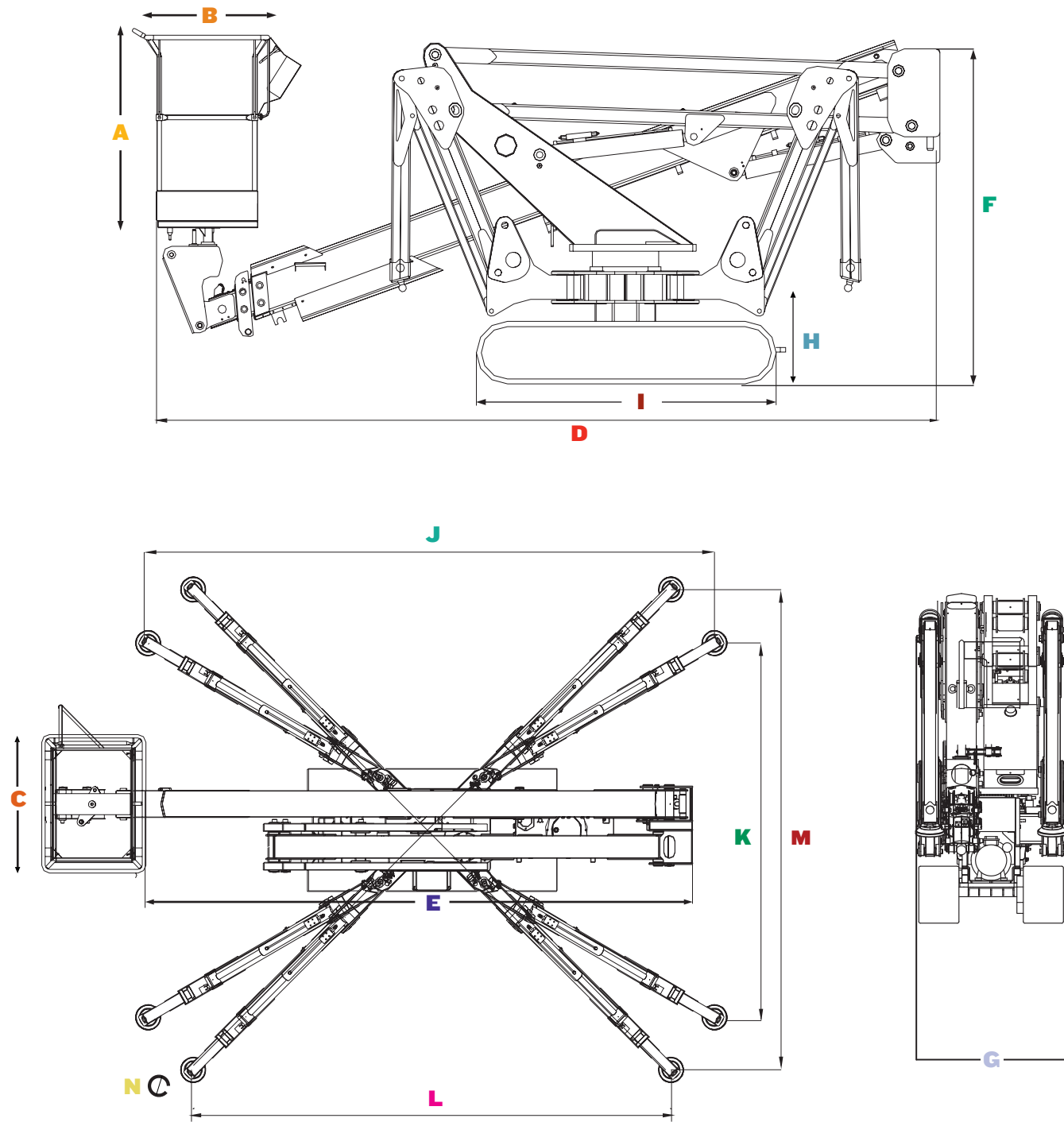

Maximum Slope to Stabilize 36%

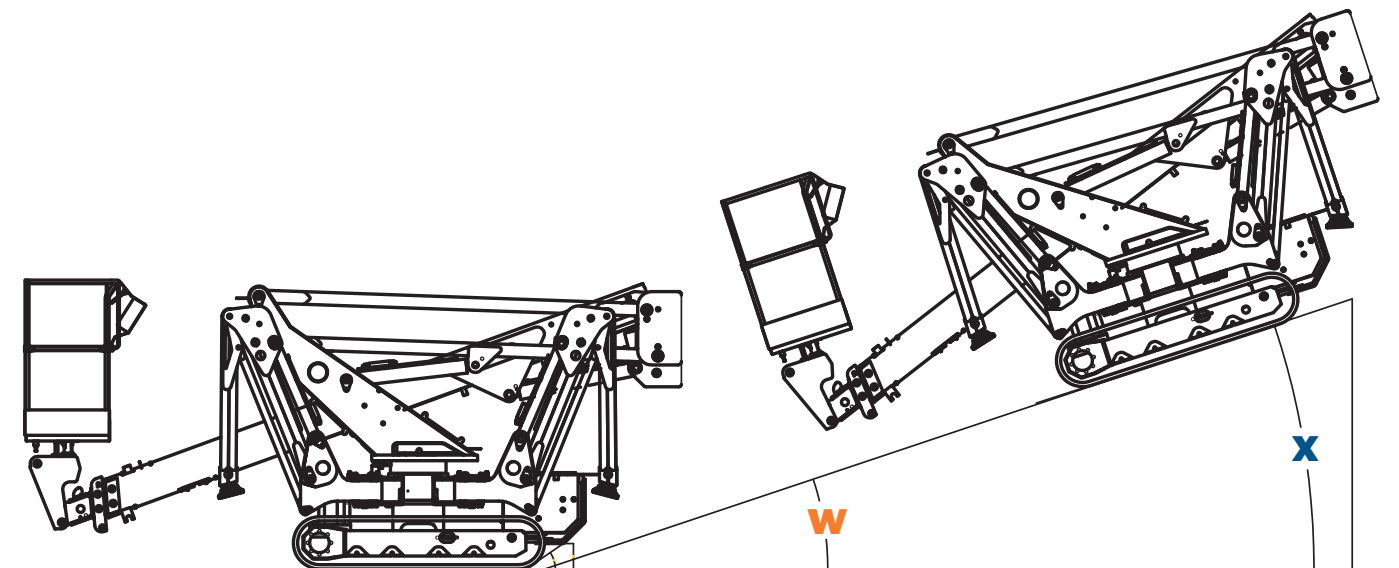

Maximum Slope Approach Angle 57%

Climbing Maximum 60.1%



Have questions? Get in touch with us:

Office: 717-684-5050  
 info@slaymakergroup.com  
 slaymakergroup.com

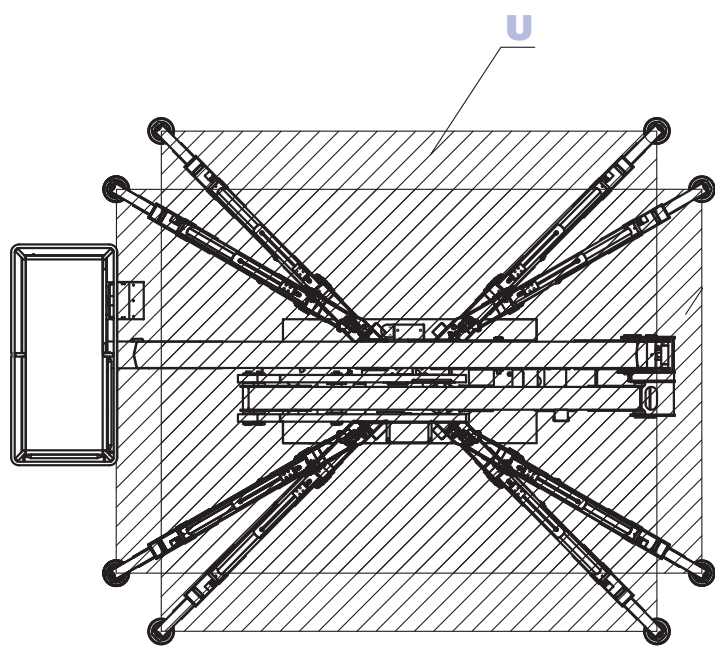
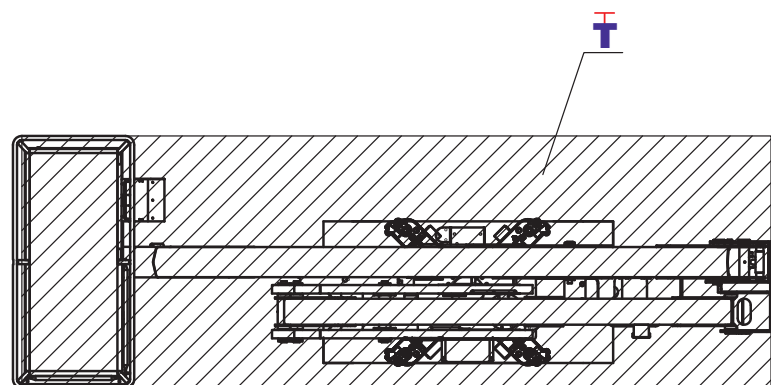
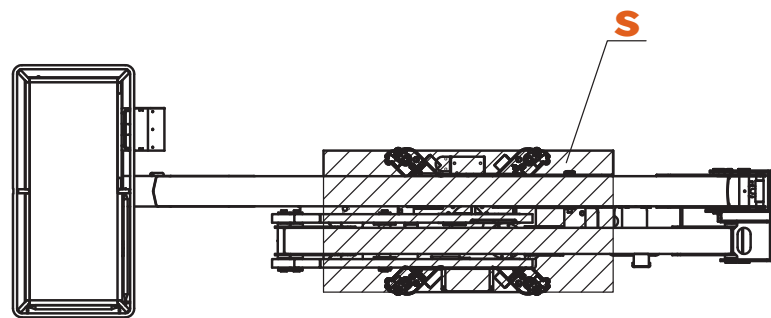

## 60HD+ ARBOR PRO Reach Diagram



485 lbs 250 lbs 200 lbs

