

# TH627

## Telehandlers



**WACKER  
NEUSON**  
*all it takes!*



### Versatile ground-engaging telehandler

The TH627 ground-engaging telehandler offers a three-in-one machine concept that provides maximum versatility. Designed with a hydraulic skid steer plate, it delivers the digging capabilities of a wheel loader, the attachment versatility of a skid steer and the performance of a leading telehandler with a lift height of 18 ft. 5 in. and 5,500 lbs. of lifting capacity. The load management system maximizes performance by automatically adjusting the position of the load to increase cycle times and minimize tipping situations.

- Three steering modes (four-wheel, two-wheel and crab steering) provide maximum maneuverability in any operating environment
- Two operator platforms are available: pressurized enclosed cab with air conditioning and heat and open canopy ROPS (rollover protection system)
- Ergonomic features include wide door for easy entry/exit, controls and multifunctional joystick are intuitive and illuminate to make selecting features easy under any lighting condition, 360° visibility of the job site and excellent line of sight to the attachment
- Diesel Oxidation Catalyst (DOC) aftertreatment requires no diesel particulate filter, no regeneration and no maintenance
- Convenient service and maintenance access reduces downtime and significantly shortens daily maintenance checks



## TH627 Technical specifications

### Operating data

Lift height max.	225.6 in
Weight	10,802.5 lb
Turning radius	144.5 in

### Engine / Motor

Engine / Motor manufacturer	Kohler
Engine performance	74.2 hp
Displacement	151.4 in <sup>3</sup>
Emission standards stage	IIIB
Sound emission at the operator's ear	79 dB(A)

### Power transmission

Traction drive	hydrostatic
Speed (standard)	0 – 18.6 mph
Axles	planetary drive steering axle
Total pivoting angle	20 °

### Steering and operating hydraulics

Steering angle	2x38 °
Duty pump	gear pump
Flow rate	23.4 US gpm
Pressure	3,481 psi

### Kinematics

Bucket capacity	1.11 yd <sup>3</sup>
Total rotation angle	150 °
Payload at max. lift height extended w/forks	3,960 lb
Payload at max. lift height retracted w/forks	5,500 lb
Payload at max. reach w/forks	2,200 lb
Range max.	124.3 in

### Filling capacities

Fuel tank capacity	26 US gal
Hydraulic oil tank	79.2 US qt

The data shown are those of the standard equipment. With the selection of further options values can vary. All rights reserved.

## TH627 Dimensions

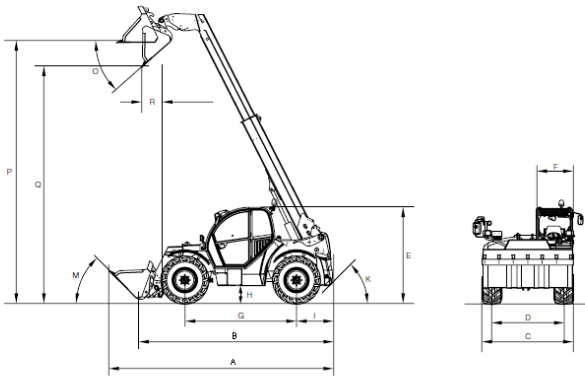

<b>A</b>	Length overall with standard bucket	195.2 in
<b>B</b>	Length overall	173.2 in
<b>C</b>	Width with standard tires	77.2 in
<b>D</b>	Track width	65.4 in
<b>E</b>	Height cabin	82.7 in
<b>F</b>	Width cabin	32.5 in
<b>G</b>	Wheelbase	104.3 in
<b>H</b>	Ground clearance	11.9 in
<b>I</b>	Center of rear axle to end of vehicle	24.4 in
<b>P</b>	Overhead loading height with standard bucket	220.5 in
<b>Q</b>	Dump height max.	207.9 in
<b>R</b>	Dump reach with standard bucket	26.8 in

Please note: that product availability can vary from country to country. It is possible that information / products may not be available in your country. More detailed information on engine power can be found in the operator's manual; the stated power may vary due to specific operating conditions. Subject to alterations and errors excepted. Applicable also to illustrations.  
Copyright © 2019 Wacker Neuson SE.