

# EZ17

## Tracked Zero Tail Excavators



**WACKER  
NEUSON**  
*all it takes!*



### Perfect balance of accessibility, speed and productivity

The EZ17 compact excavator is the best performing zero tail model in its class. The EZ17 is powered by a Tier 4 Final engine that offers excellent power, fuel economy and quiet operation. The EZ17 is the smallest zero tail excavator from Wacker Neuson combining a compact design, expandable undercarriage and 2-speed drive. The EZ17 provides maximum maneuverability and accessibility while still delivering an excellent digging depth and powerful bucket breakout force. The expandable undercarriage is adjustable to travel through narrow passages and low ground pressure protects existing landscaping.

- Load sensing system (LUDV) offers smoother operation and improved performance when using multiple functions.
- A telescopic undercarriage can be extended from 39" to 51" for greater lifting power and stability.
- 2-speed drive offers travel speeds up to 2.9 mph.
- Pattern control changeover allows for ISO and SAE operation.
- Positioning of boom cylinder on top of the boom offers great boom and hose protection.

## EZ17 Technical specifications

### Operating data

Shipping weight min.	3,516 lb
Operating weight	3,801 - 4,299 lb
Biting force max.	2,046 lbf
Breakout force max.	4,204 lbf
Digging depth max.	97.9 in
Dumping height	95.9 - 100.47 in
Digging radius max.	153.5 in
L x W x H	141.1 x 39 x 93 in

### Engine / Motor

Engine / Motor manufacturer	Yanmar
Engine / Motor type	3TNV80F
Engine / Motor	Water-cooled 3-cylinder diesel engine
Displacement	77.2 in <sup>3</sup>
RPM / speed	2,200 rpm
Engine performance output to ISO	17.2 hp
Battery	30 CCA
Fuel tank capacity	5.8 US gal

### Hydraulic system

Flow rate	10.5 US gpm
Operating pressure for working and traction hydraulics	3,481 psi
Operating pressure Slewing gear	2,176 psi
Hydraulic oil tank	5.6 US gal

### Undercarriage

Travel speed max.	3 mph
Chain width	9.1 in
Ground clearance	6.3 in

### Dozer Blade

Width	51.2 in
Height	9.1 in

### Sound level

Sound level (LwA) acc. to 2000/14/EC	93 dB(A)
Cabin - specified sound pressure level LpA acc. to ISO 6394	79 dB(A)

## EZ17 Dimensions

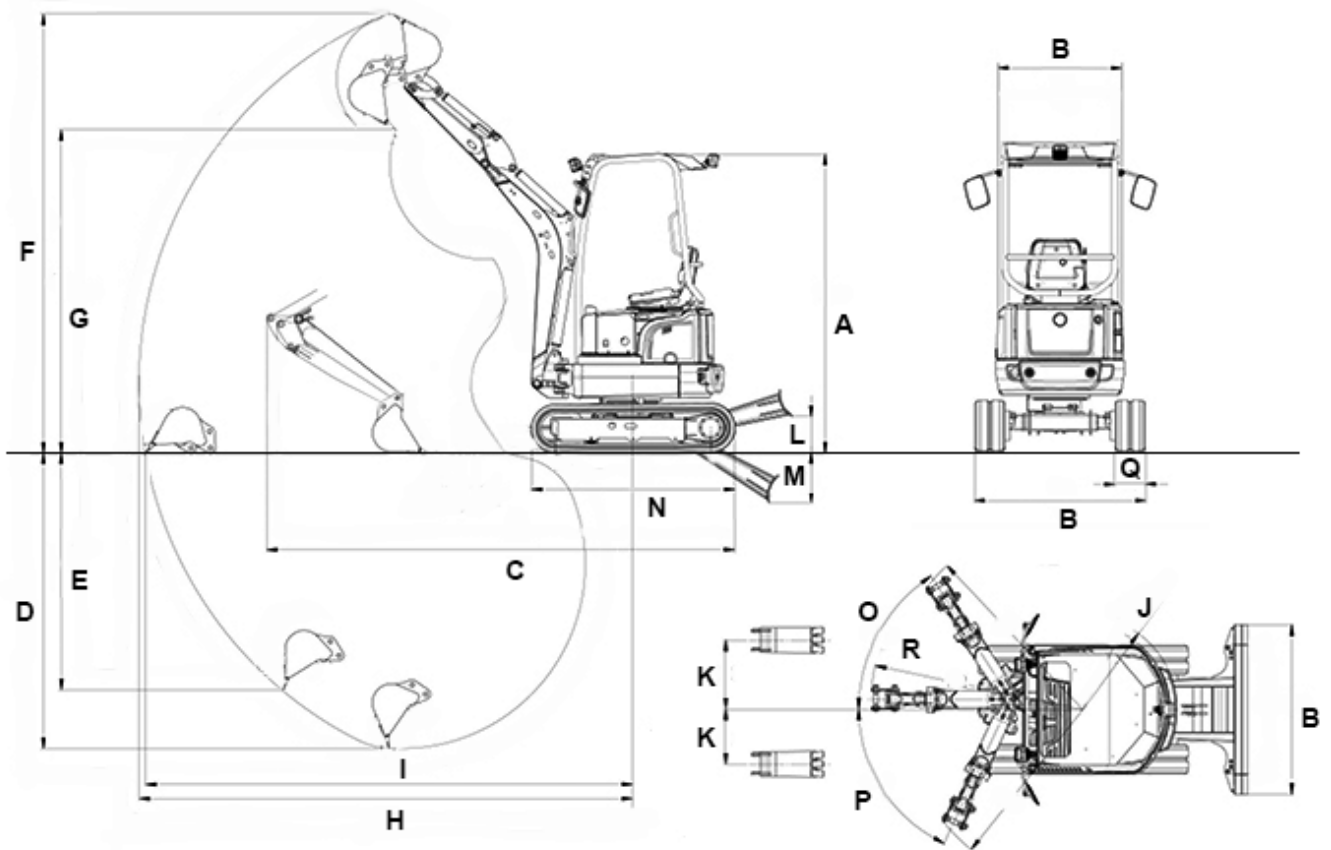

A	Height	93 in
B	Width - Canopy	34.8 in
B	Width - Undercarriage retracted	39 in
B	Width - Undercarriage extended	51.2 in
C	Transport length - Standard Dipperstick	141.1 in
C	Transport length - Long Dipperstick	139.8 in
D	Digging depth max. - Standard Dipperstick	91.6 in
D	Digging depth max. - Long Dipperstick	97.9 in
E	Insertion depth - Standard Dipperstick	67.4 in
E	Insertion depth - Long Dipperstick	73.4 in
F	Insertion height - Standard Dipperstick	136.3 in
F	Insertion height - Long Dipperstick	140.8 in
G	Dump height max. - Standard Dipperstick	95.9 in
G	Dump height max. - Long Dipperstick	100.4 in
H	Digging radius max. - Standard Dipperstick	153.5 in
H	Digging radius max. - Long Dipperstick	159.4 in
I	Range - Standard Dipperstick	151.5 in
I	Range - Long Dipperstick	157.6 in
J	Rear swivel radius	26 in

K	Arm displacement to centre of bucket, right side	21 in
K	Arm displacement to centre of bucket, left side	16.5 in
L	Lift height -Above ground	10.7 in
M	Scraping depth - Below ground	15.4 in
N	Length - Track	63.3 in
O	Turning angle - Boom system to the right	57 °
P	Turning angle - Boom system to the left	65 °
Q	Chain width	9.1 in
R	Boom slewing radius - Middle	64.1 in
--	Boom slewing radius - Right	59.8 in
--	Boom slewing radius - Left	54 in
--	Height - Dozer blade	9.1 in

Please note: that product availability can vary from country to country. It is possible that information / products may not be available in your country. More detailed information on engine power can be found in the operator's manual; the stated power may vary due to specific operating conditions. Subject to alterations and errors excepted. Applicable also to illustrations.  
 Copyright © 2019 Wacker Neuson SE.