



70Z Mini Excavator

- Zero Front Swing
- Zero Tail Swing
- 57 hp water cooled diesel engine
- Fully Enclosed. A/C and Heated Cab
- A-F Quick Change Control Valve
- Hydraulic knuckle boom
- 2-Speed Travel
- Auxiliary hydraulics standard
- Hydraulic pilot controls

GENERAL

Canopy	Cabin
Bucket Capacity	8.82 cu. ft.
Operating Weight	16,055 lbs.
Transportation Weight	15,455 lbs.

ENGINE

Model	Isuzu AA4JG1
Horsepower	57 hp @ 2,100 rpm
Fuel Tank Capacity	19.8 gallons

FEATURES

Travel Speed L/H	1.7/3.1 mph
Ground Pressure	4.6 psi
Swing Speed	9.2 rpm
Swing Angle	L50°/R90°

HYDRAULIC EQUIPMENT

Pumps	4 Pump
Pump Type	2 Piston / 2 Gear
Total Flow	52 gpm
Operating Pressure	3,555 psi
Auxiliary Flow	19 gpm

DIMENSIONS

Total Length	18'2"
Total Width	7'3"
Total Height	8'5"

Dimensions

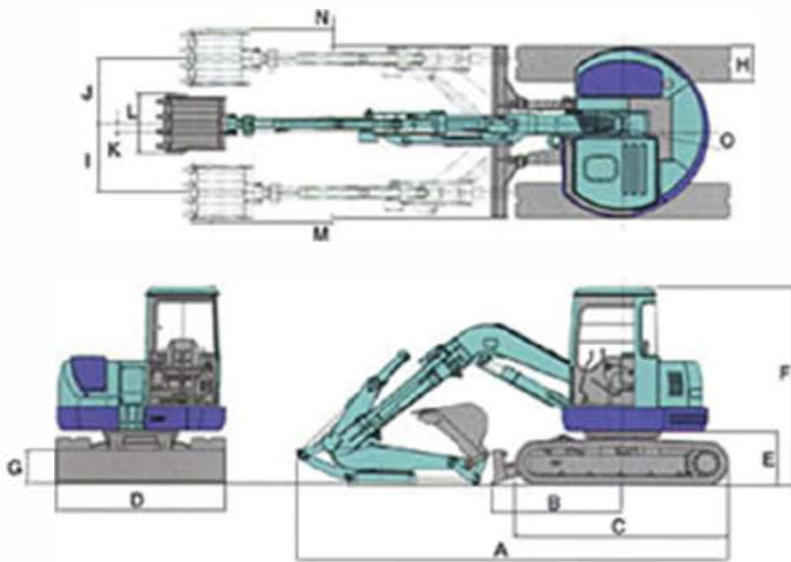

A	18'2"	I	7'3"
B	5'6"	J	2'9"
C	9'0"	K	4"
D	7'3"	L	2'6"
E	2'4"	M	2"
F	8'6"	N	9"
G	1'6"	O	3'7"
H	1'6"	P	

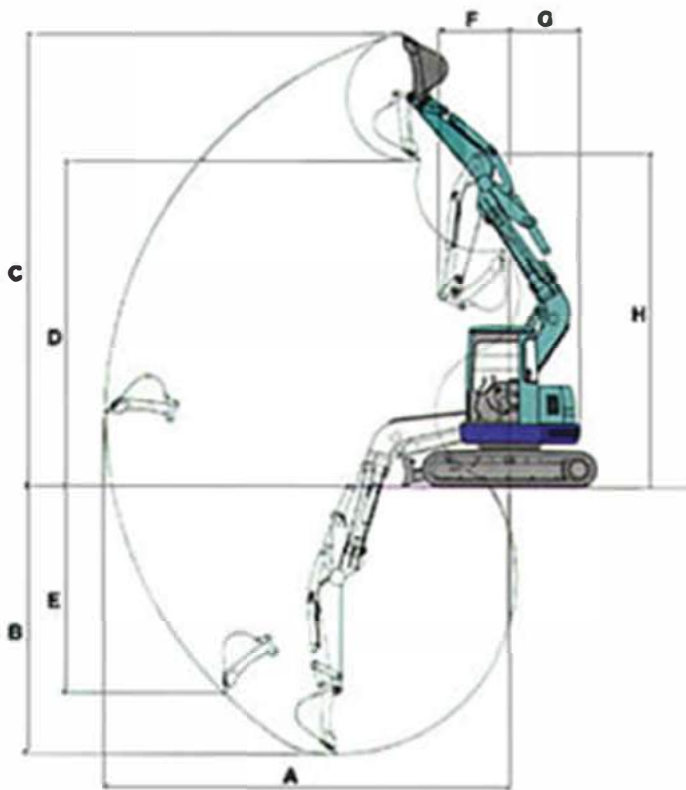

A	Max Digging Radius	20'9"
B	Max Digging Depth	14'1"
C	Max Digging Height	23'7"
D	Max Dumping Height	16'11"
E	Max Vertical Digging Depth	14'1"
F	Min Front Turning Radius	3'7"
	At Right Boom Swing	3'7"
	Digging Force	14,730 lbs.