

SLAYMAKER RENTALS
888-392-4708
slaymakergroup.com
☑ Rentals ☑ Sales ☑ Service ☑ Parts



Maximum lifting height: 58 ft
Maximum reach: 47 ft
Electronically controlled hydrostatic transmission
Automatic leveling device
Pivoting stabilizers

RTH 4.18 SMART

MACHINE MODEL	Rotating telescopic handler	RTH 4.18 Smart	
	Maximum lifting capacity	8.800 lbs (center of gravity 24 in)	
	Maximum lifting height	58 ft	
	Rotation	400° (limited)	
ENGINE	Type	Deutz TCD 3.6 L4 - stage IV	Deutz TCD 3.6 L4 - stage IIIA compliant
	Rated power	55.4 kW - 74 HP to 2,200 rpm	55.4 kW - 74 HP to 2,200 rpm
	Maximum torque	390 Nm at 1,300 rpm	390 Nm at 1,300 rpm
	Displacement	0.95 US gal	0.9t US gal
	Cylinders	4 in line	4 in line
	Fuel	Turbocharged direct injection diesel	Turbocharged direct injection diesel
	Cooling system	Water - intercooler	Water - intercooler
TRANSMISSION	Type	Hydrostatic	
	Model	Bosch - Rexroth	
	Maximum pressure	500 bar	
	Displacements	Electronically controlled Variable displacement pump Variable displacement motor	
	Gear box	Dropbox, 2 speeds forward-reverse	
AXLES AND BRAKES	Type	Axles with planetary gearboxes	
	Rear axle	Steering	
	Front axle	Oscillating and steering with levelling +/-10°	
	Service brake	Hydraulically operated wet multi-disk brakes on each axle	
	Parking brake	Hydraulic with negative action	
	Tires dimensions	18 R19.5 (445/65 R19.5)	
PERFORMANCE	Max. travel speed	15 Mph	
	Drawbar pull	83 kN	
	Gradeability	41%	
	Turning radius (end of forks)	240,7 in	
WEIGHTS	Total unladen	32,518 lbs	
	Front axle unladen (boom retracted and lowered)	15,433 lbs	
	Rear axle unladen (boom retracted and lowered)	17,085 lbs	
TANK AND SYSTEM CAPACITIES	Fuel tank	47 US gal	47 US gal
	AdBlue	3 US gal	n.a.
	Hydraulic oil tank	43.5 US gal	43.5 US gal
	Engine oil tank	2 US gal	2 US gal
	Cooling liquid	6 US gal	6 US gal
HYDRAULIC CIRCUIT FOR MOVEMENTS	Max. operating system pressure	270 bar	
	Circuit type	Load sensing	
	Service pump	Gear pump	
	Controls for boom and turret movements	Danfoss - SIL 2 electro-proportional valve	
	Controls for stabilizers	Bosch Rexroth - Electro-hydraulics controls	
	Movements control	2 no. two-axis Danfoss joysticks with deadman safety device - Managed via CAN bus	
STANDARDS MET	EN 13849: concerning the safety of all machine controls EN 13000: concerning standards for hydraulic cranes EN 280: concerning standards for mobile elevating work platforms FOPS/ROPS EU 2016/1628: concerning engine emissions standards EN 1459-2: concerning standards for slewing variable-reach trucks		

The data in this brochure are informative and subject to change without notice

REV08.A

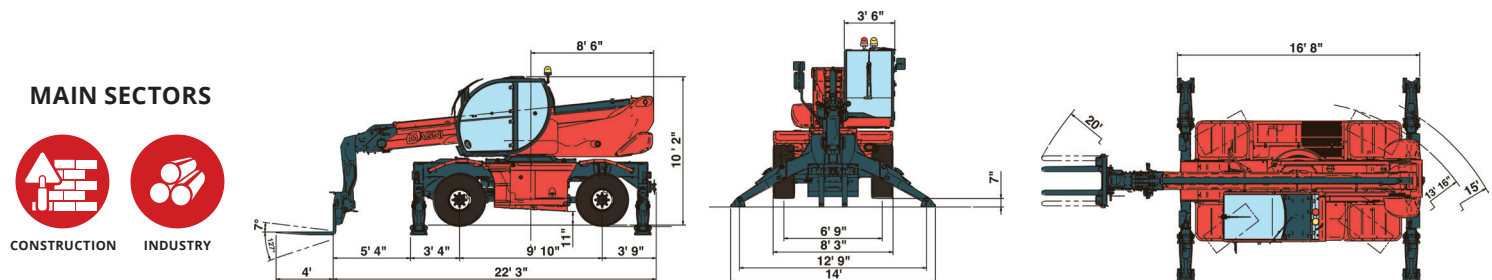

Magni Telescopic Handlers srl
 Via Magellano, 22 - 41013 Castelfranco Emilia, Modena, Italia - Tel: +39 059 8630811 - Fax: +39 059 8638012
 commerciale@magnith.com - www.magnith.com

**360° LOAD CHART
ON FULLY EXTENDED STABILIZERS**

ON STABILIZERS

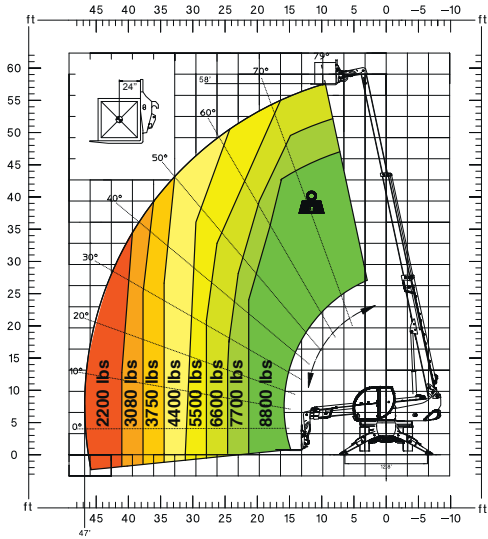

ON TIRES

FRONT LOAD CHART ON TIRES

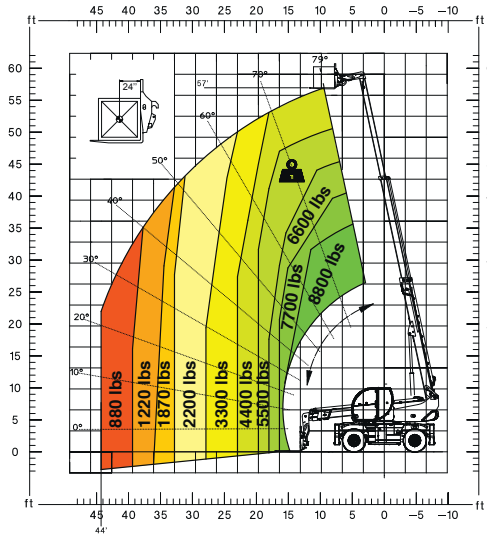

HOOK 8,800 lbs

H 4

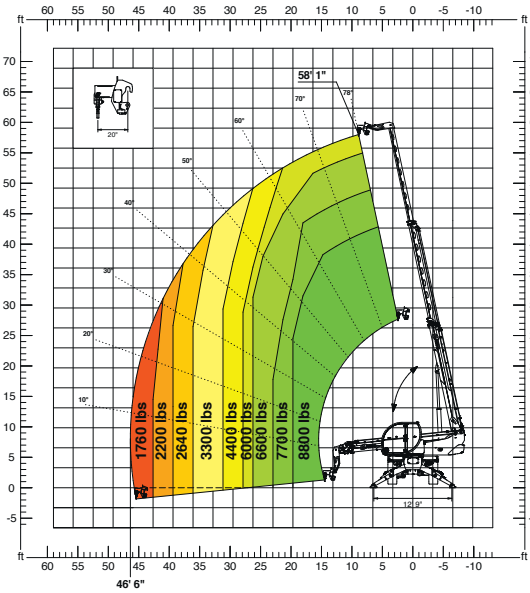

WINCH 8,800 lbs

W 4

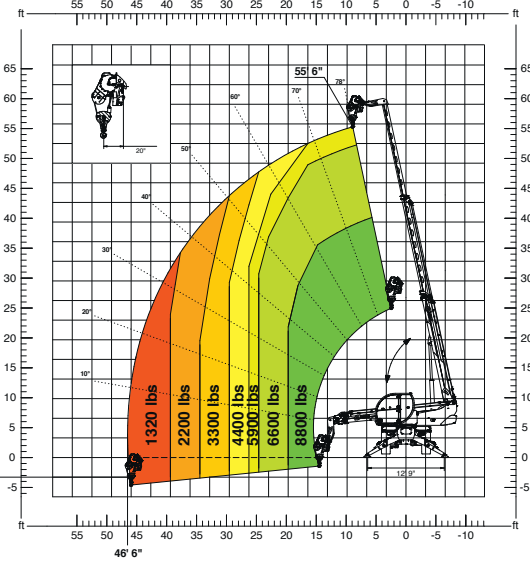

JIB 3,960 lbs

J 1800

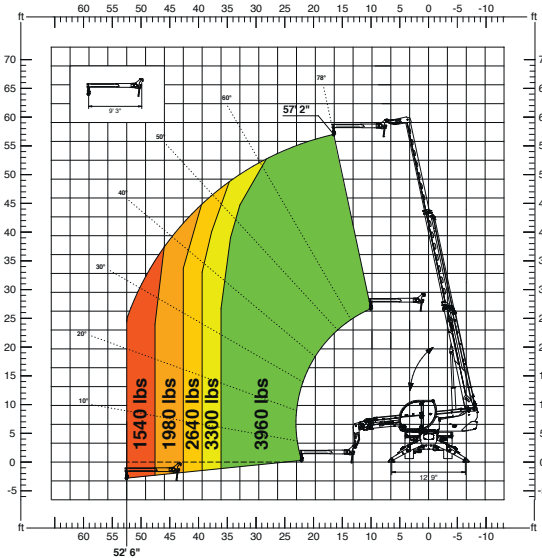

JIB WINCH 1,320 lbs

JW 600

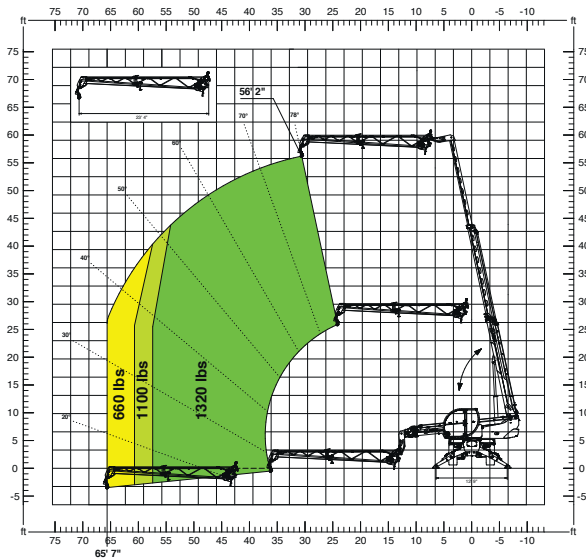

JIB WINCH **4,400 lbs**

JW 2000

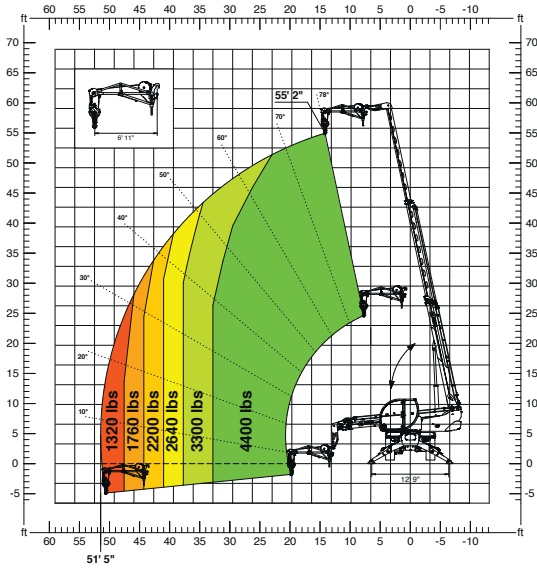

ROTATING EXTENDABLE BASKET **1,100 lbs**

REP 2-4,5

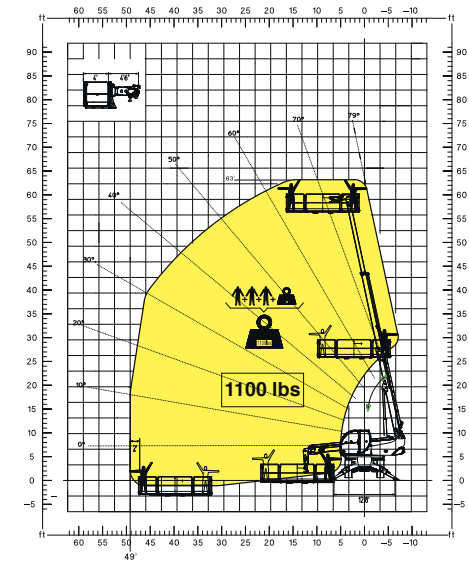

ROTATING EXTENDABLE BASKET **2,200 lbs**

REP 10.2-4,7

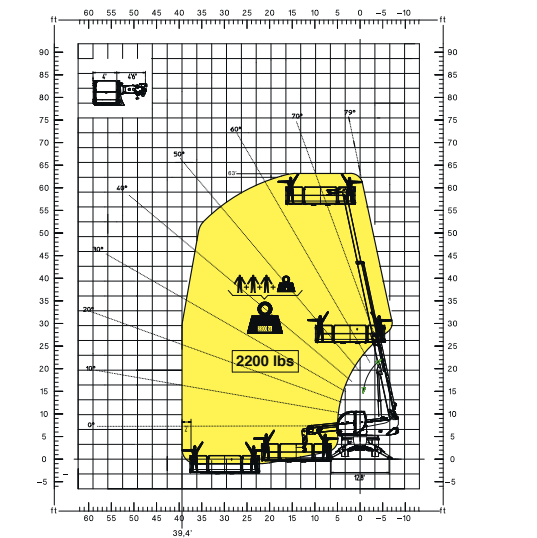

TELESCOPIC PIVOTING BASKET WITH 180° ROTATION

TP

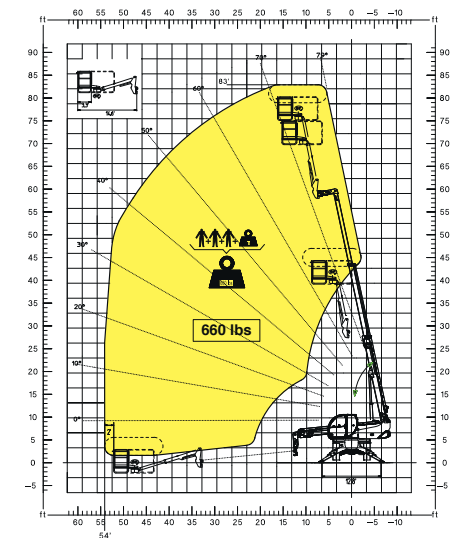

TELESCOPIC PIVOTING OVER-UNDER BASKET WITH 340° ROTATION

TP O-U

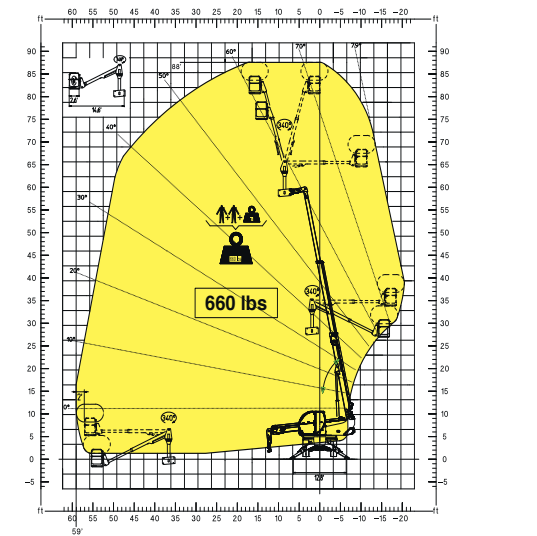

TELESCOPIC PIVOTING OVER-UNDER BASKET WITH 340° ROTATION

TP O-U

